

INSTALLATION, OPERATION AND MAINTENANCE INSTRUCTIONS FOR NEB700 700-LUMEN FLUORESCENT EMERGENCY BALLAST

IMPORTANT SAFEGUARDS:

When using electrical equipment, always adhere to basic safety precautions including the following:

EMERGENCY BALLAST OVERVIEW

The NEB700 Emergency Ballast allows the same indoor fixture to be used for both normal and emergency operation. In the event of a power failure, the NEB700 switches to the emergency mode and operates one or two of the existing lamps for a minimum of 90 minutes.

The NEB700 contains a battery, charger and inverter circuit in a single package. It can be mounted in the wireway or on top of the indoor fixture and is UL Listed for factory installation or retrofit applications.

LAMP COMPATIBILITY

In the emergency mode, this device will operate one (1) 2' to 4' rapid start, instant start or energy-saving T8-T12; one (1) or two (2) 2'-8" rapid, instant, or energy savings T8-T12, HO, VHO; one (1) or two (2) 20W-40W Circline lamp; one (1) 13W, 18W, or 26W 4-pin compact fluorescent lamp; one (1) 13W-42W twin, quad or triple (4-pin) compact fluorescent lamp; one (1) 40W Biac; one (1) 50W Biac; or one (1) 55W Biac.

IMPORTANT SAFEGUARDS

When using electrical equipment, always adhere to basic safety precautions, including the following:

READ AND FOLLOW ALL SAFETY INSTRUCTIONS

1. Do not use outdoors. This unit is for use with grounded, UL Listed indoor fixtures except in heated air outlets or in wet, damp or hazardous locations.
2. This device is designed for factory or field installation in either the wireway or on top of the indoor fixture.
3. This device should be mounted in locations and at heights where it will not be easily subjected to tampering by unauthorized personnel.
4. Do not install near gas or electric heaters.
5. Do not use this equipment for anything other than its intended use.
6. The use of accessory equipment not recommended by the manufacturer will void product listing and warranty and may cause an unsafe condition.
7. Prior to installation, battery connection must be open to prevent high

voltage from being present on the output leads (red and yellow).

8. A continuous AC power source of 120VAC or 277VAC is required.
9. Make sure electrical connections are in conformance with the National Electrical Code (NEC) and local regulations where applicable.
10. To prevent electric shock, disconnect normal and emergency power supplies and battery connections from the emergency ballast before servicing.
11. This is a sealed unit that contains a maintenance-free, high temperature nickel-cadmium (Ni-Cad) battery that is not replaceable in the field. Do not attempt to service or replace battery. Replace entire unit when necessary. Batteries must be recycled or disposed of properly. Contact manufacturer for information.
12. Installation or service on this equipment should be performed by qualified personnel only.

DIAGRAM 1

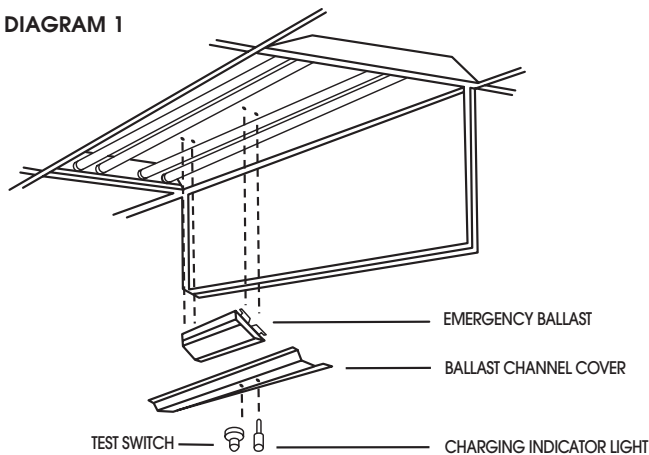

DIAGRAM 2

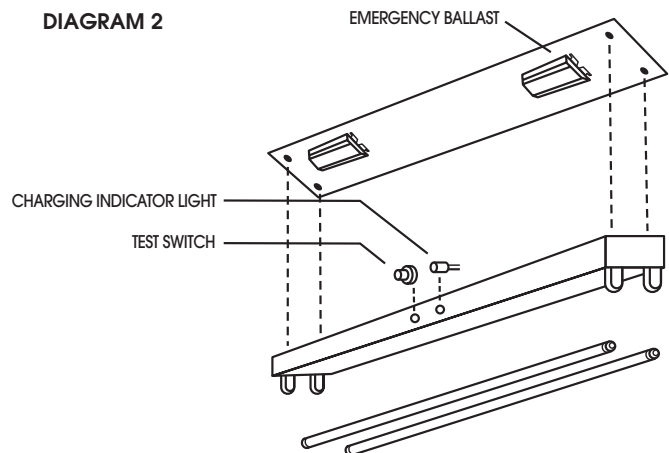
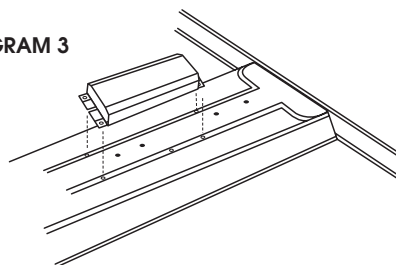

DIAGRAM 3



INSTALLATION, OPERATION AND MAINTENANCE INSTRUCTIONS FOR NEB700 700-LUMEN FLUORESCENT EMERGENCY BALLAST

SAVE THESE INSTRUCTIONS

INSTALLATION

1. Turn off AC power before installation.
2. Choose proper wiring diagram (Page 3) to connect this emergency ballast to AC ballast and lamp.
3. Emergency ballast must be fed from the same branch circuit as the AC ballast.
4. Follow directions to install emergency ballast on top of fixture or in ballast channel (Diagrams 2 and 3).
5. The TEST switch should be installed either through the side of strip fixture or troffer cover in ballast channel. Follow directions to drill a small hole and install TEST switch (Diagram 1 & 2). Wire the TEST switch so that it disconnects AC power from both the emergency ballast and AC ballast at the same time (Diagram 4).
6. Install the CHARGE indicator by connecting the violet and brown leads (Diagram 5). The CHARGE indicator light should be illuminated during normal fixture operation.
7. Place appropriate labels on CHARGE indicator light and TEST switch upon completion of installation.
8. Select a highly visible location and adhere warning label that states, (CAUTION: This unit has more than one power supply connection point. To reduce the risk of electric shock, disconnect both the branch circuit breakers or fuses and emergency power supplies before servicing.)
9. Wire nut unused AC voltage lead.
10. Turn on AC power.
11. When the fixture is completely installed, connect the battery.
12. Check to see that CHARGE indicator light is illuminated.
13. Battery in emergency ballast must be charged for one (1) hour in order to perform short-term emergency function testing. Before attempting a long-term emergency function test (90 minutes), battery must be charged for 24 hours.

OPERATION

1. The CHARGE indicator light should be illuminated when AC power is applied.
2. Emergency ballast should function and operate one (1) lamp for at least 90 minutes after AC power has failed.

MAINTENANCE

1. To ensure that emergency ballast is operating properly, the following schedule is recommended:
 - a. Every month - Visually inspect CHARGE indicator and confirm illumination.
 - b. Every month - Press TEST switch for 30 seconds and confirm lamp operation at reduced illumination.
 - c. Every year - Perform a 90-minute long-term emergency function test to be sure lamp operates at reduced illumination for a minimum of 90 minutes.
2. Written records of testing shall be kept by the owner for inspection by the authority having jurisdiction.

DIAGRAM 4

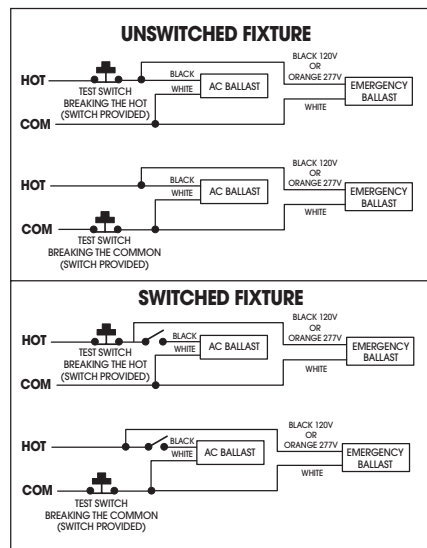
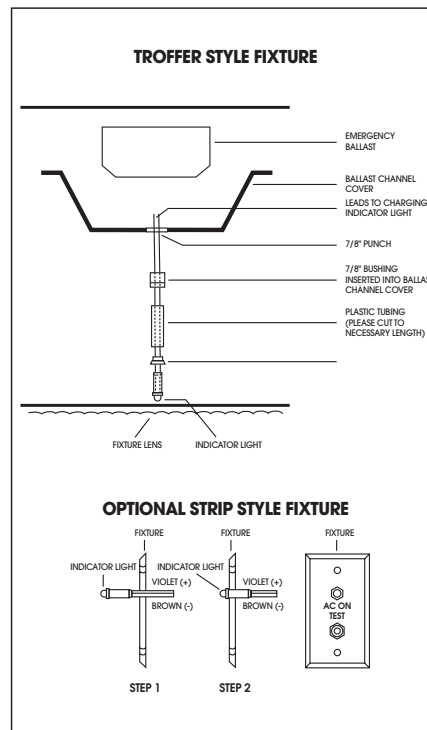

DIAGRAM 5



WIRE DIAGRAMS FOR 1 LAMP EMERGENCY OPERATION

EMERGENCY BALLAST AND AC BALLAST MUST BE FED FROM THE SAME BRANCH CIRCUIT

TYPICAL SCHEMATICS ONLY. MAY BE USED WITH OTHER BALLASTS. CONSULT THE FACTORY FOR OTHER WIRING DIAGRAMS.

FOR 1 LAMP FIXTURE

A. RAPID START AC BALLAST

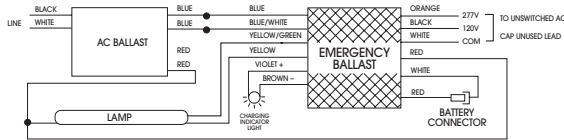

B. INSTANT START SLIMLINE BALLAST

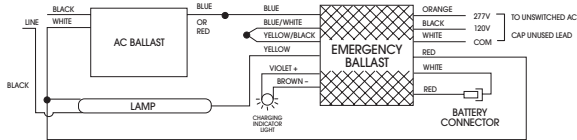

C. CIRCLINE RAPID START BALLAST

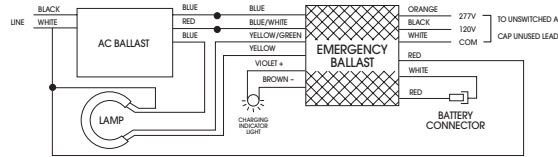

FOR 3 LAMP FIXTURE

RAPID START

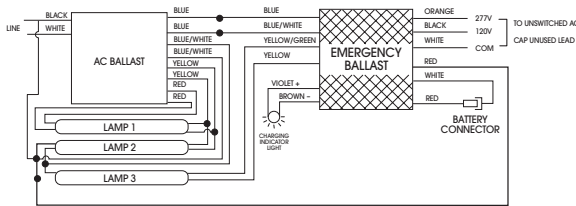

EMERGENCY ONLY

ONE (1) LAMP WITHOUT AC BALLAST

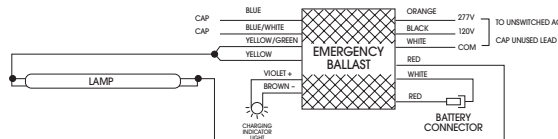

FOR 2 LAMP FIXTURE

A. INSTANT START SLIMLINE BALLAST

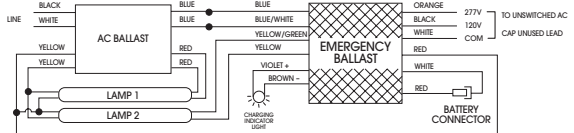

B. LEAD/LAG INSTANT START SLIMLINE BALLAST

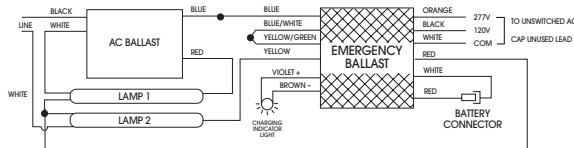

C. SERVES SEQUENCE INSTANT START BALLAST

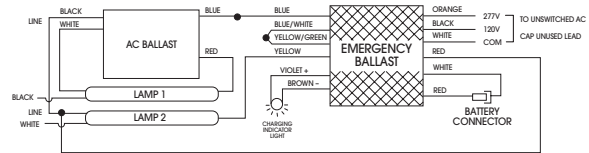

D. INSTANT START ELECTRONIC BALLAST

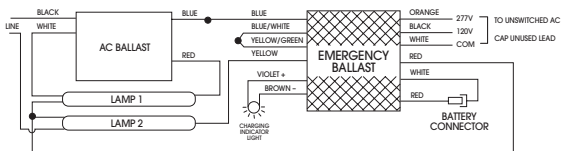

E. CIRCLINE RAPID START BALLAST

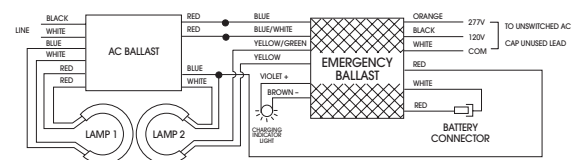

Navilite™

Exit and Emergency Lighting

INSTALLATION INSTRUCTIONS

INSTALLATION, OPERATION AND MAINTENANCE INSTRUCTIONS FOR NEB700 700-LUMEN FLUORESCENT EMERGENCY BALLAST

WARRANTY

Juno Lighting Group warrants that its products are free from defects in material and workmanship. Juno Lighting Group's obligation is expressly limited to repair or replacement, without charge, at Juno Lighting Group's factory after prior written return authorization has been granted. This warranty shall not apply to products which have been altered or repaired outside of Juno Lighting Group's factory. This warranty is in lieu of all other warranties, expressed or implied, and without limiting the generality of the foregoing phrase, excludes any implied warranty of merchantability. Also, there are no warranties which extend beyond the description of the product on the company's literature setting forth terms of sale.

Product Services Phone (888) 387-2212

1300 S. Wolf Rd • P.O. Box 5065 • Des Plaines, IL 60017-5065 • Phone: 800-323-5068 • www.junolightinggroup.com JUNO LIGHTING GROUP

